

# Surface Area

# 3

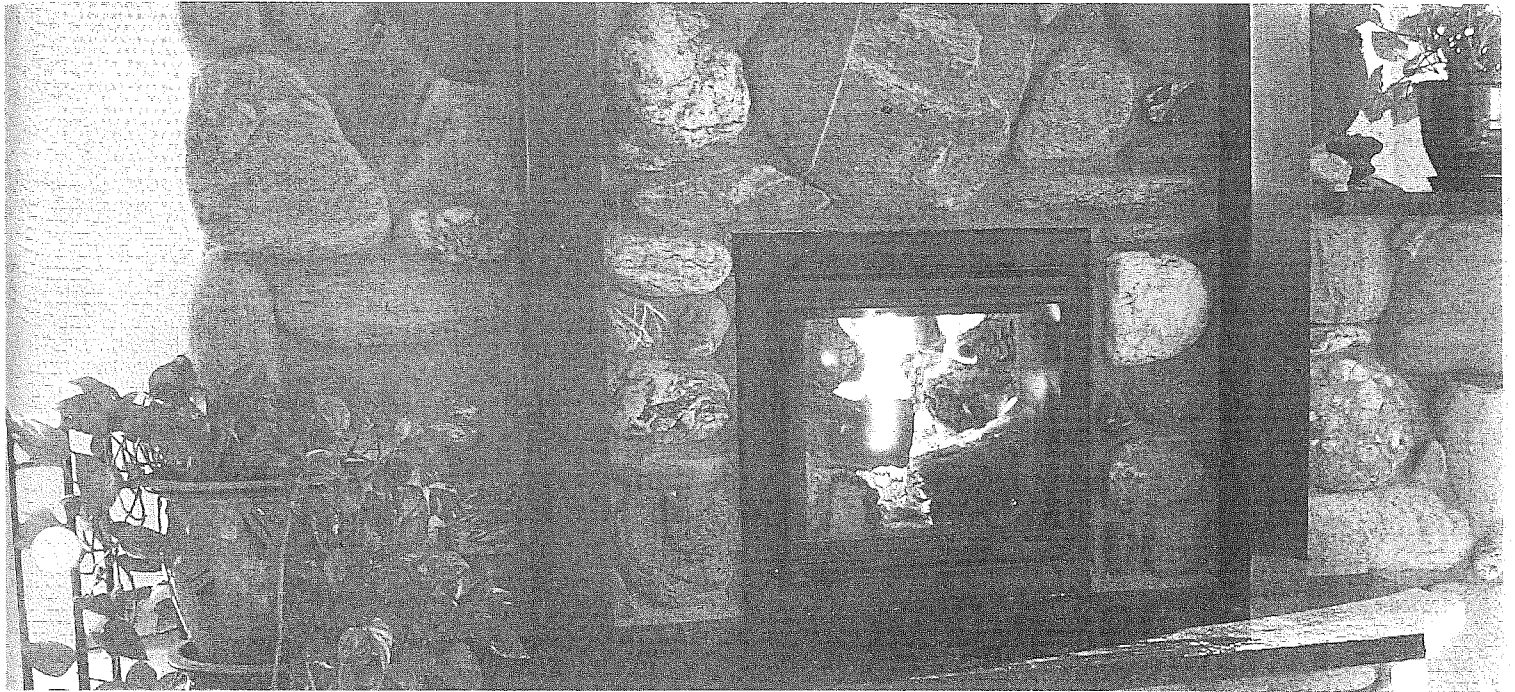

A masonry stove stores heat in its stones or bricks. The surface area of the stove determines how much space it can heat.

- A. Carys plans to finish her basement. She needs a stove with a surface area that is at least 80 sq ft to heat the basement. How can she determine whether a stove is large enough?

---

---

---

- B. Describe another job in finishing the basement for which Carys might need to determine a surface area.

---

---

# 3

## Getting Started

1. Match each area to an object it could describe.

- |                   |                 |
|-------------------|-----------------|
| 4 cm <sup>2</sup> | a cellphone     |
| 1 sq ft           | a bed           |
| 2 m <sup>2</sup>  | a postage stamp |
| 8 sq in.          | a window        |
| 1 sq yd           | a binder        |

2. Evaluate.

- a)  $(23.5 \text{ m})^2 = \underline{\hspace{2cm}} \text{ m}^2$   
 b)  $\sqrt{25 \text{ cm}^2 + 144 \text{ cm}^2} = \underline{\hspace{2cm}} \text{ cm}$

3. The area of a polygon is the number of square units of space that it covers. Name each polygon and determine its area.

areas of polygons  
rectangle

$$A = (\text{length})(\text{width}) \\ = lw$$

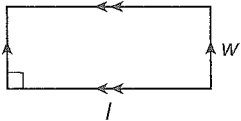

triangle

$$A = \frac{1}{2}(\text{base})(\text{height}) \\ = \frac{1}{2}bh$$

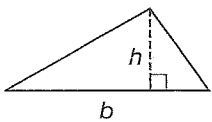

parallelogram

$$A = bh$$

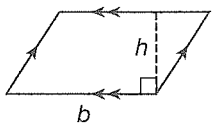

trapezoid

$$A = \frac{1}{2}(b + B)h$$

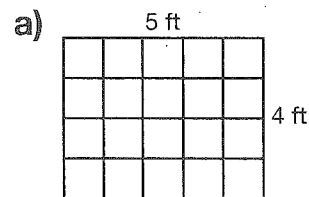
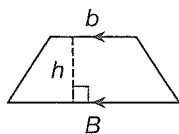

Name of polygon: \_\_\_\_\_

$$\text{Area} = \underline{\hspace{1cm}} \text{ ft} \times \underline{\hspace{1cm}} \text{ ft} \\ = \underline{\hspace{1cm}} \text{ sq ft}$$

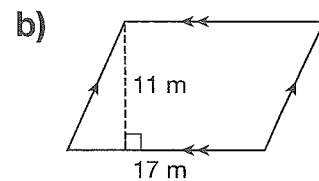

Name of polygon: \_\_\_\_\_

$$\text{Area} = \underline{\hspace{2cm}} \\ = \underline{\hspace{2cm}}$$

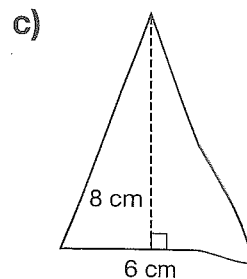

Name of polygon: \_\_\_\_\_

$$\text{Area} = \underline{\hspace{2cm}} \\ = \underline{\hspace{2cm}} \text{ cm}^2$$

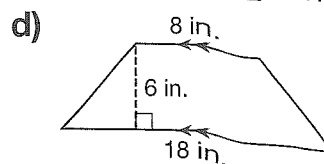

Name of polygon: \_\_\_\_\_

$$\text{Area} = \underline{\hspace{2cm}} \\ = \underline{\hspace{2cm}}$$

4. Determine the circumference and area of each circle, to the nearest unit.

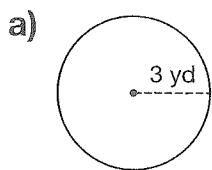

$$C = 2\pi(\text{ } \_\_\_\_\_\_ \text{ yd})$$

$$= \text{ } \_\_\_\_\_\_ \text{ yd,}$$

or about  $\text{ } \_\_\_\_\_\_ \text{ yd}$

$$A = \pi(\text{ } \_\_\_\_\_\_ \text{ yd})^2$$

$$= \text{ } \_\_\_\_\_\_ \text{ sq yd,}$$

or about  $\text{ } \_\_\_\_\_\_ \text{ sq yd}$

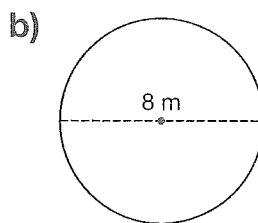

$$C = \text{ } \_\_\_\_\_\_ (\text{ } \_\_\_\_\_\_ \text{ m})$$

$$= \text{ } \_\_\_\_\_\_ \text{ m,}$$

or about  $\text{ } \_\_\_\_\_\_ \text{ m}$

$$r = \frac{1}{2}(\text{ } \_\_\_\_\_\_ \text{ m})$$

$$= \text{ } \_\_\_\_\_\_ \text{ m}$$

$$A = \text{ } \_\_\_\_\_\_ (\text{ } \_\_\_\_\_\_ \text{ m})^2$$

$$= \text{ } \_\_\_\_\_\_ \text{ m}^2,$$

or about  $\text{ } \_\_\_\_\_\_ \text{ m}^2$

**circle formulas**

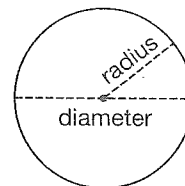

**circumference**

$$C = \pi \times (\text{diameter})$$

or

$$C = 2\pi \times (\text{radius})$$

**area**

$$A = \pi \times (\text{radius})^2$$

**Tech Tip**

**Pi**

Some calculators have a special key for  $\pi$ . If your calculator does not, use 3.14 as an estimate for  $\pi$ .

5. Toula works at an aquarium store. She uses area formulas to estimate how many fish an aquarium can hold. For freshwater tropical fish, the formula is

$$\text{Area of top of tank} \div 12 \text{ sq in.} = \text{number of fish}$$

How many freshwater tropical fish can live in this aquarium?

6. Toula's aquarium, on the right, is 24 in. high. What is the total area of all of its outside surfaces in square inches? Include the top and bottom.

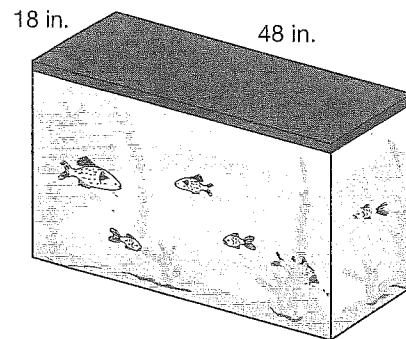

**Hint**

Use the charts inside the back cover.

# 3.1

## Relating Nets to Surface Area

### Try These

**You will need**

- a small box
- a ruler
- a compass

Trace the faces of a small box, and draw its net.

- How many faces does your box have? \_\_\_\_\_
- What is the total area of all the faces? \_\_\_\_\_

**net**

a composite 2-D shape that can be folded to create a 3-D object

Maia built this wooden cabinet. She plans to use 2 coats of maple stain on the outside surfaces. This includes the bottom and the door. A 1 L can of stain covers 80 sq ft.

Is one can enough to stain the cabinet?

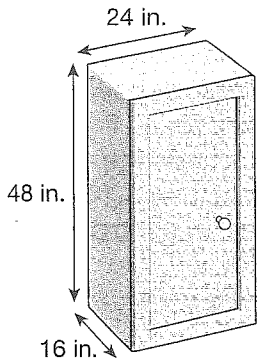

- This is a net for the cabinet. Some measurements are done for you. Record the length and width of each rectangular face. Then record the area of each face in square inches.

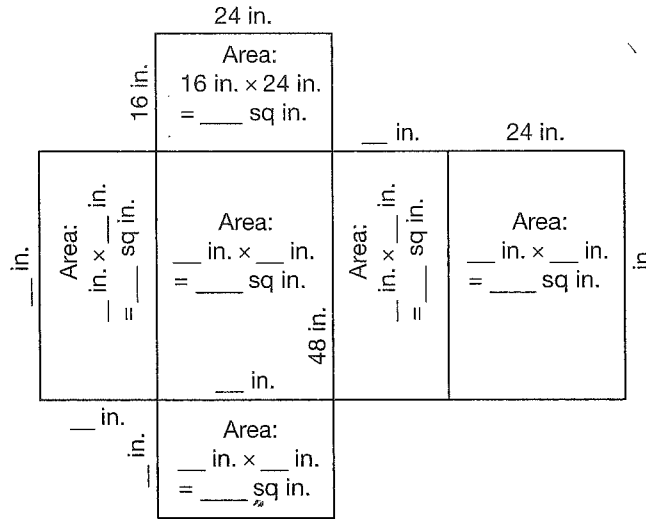

### REFLECTING

What are some other ways to draw the net for this cabinet?

- What is the total surface area of the cabinet in square inches?  
 $2(\text{___ sq in.}) + 2(\text{___ sq in.}) + 2(\text{___ sq in.}) = \text{___ sq in.}$

- Will 1 can of stain be enough for 2 coats?  
 Stain needed:  $2 \times \text{___ sq in.} = \text{___ sq in.}$

**Hint**

1 sq ft = 144 sq in.

One can covers:  $\text{___ sq ft} \times \frac{\text{___ sq in.}}{1 \text{ sq ft}} = \text{___ sq in.}$   
 $\text{___ sq in.} < \text{___ sq in.}$  So \_\_\_\_\_.

## Example

The North End Water Pollution Control Centre in Winnipeg has cylindrical tanks. Bacteria in the tanks clean wastewater. Each tank has a radius of 16.5 m and is 8.6 m high. Maintenance staff paint the tops and sides of the tanks.

What surface area needs to be painted for each tank, to the nearest square metre?

### Solution

- A. This net represents a tank. Label the measurements of the width of the rectangle and the radius of each circle.

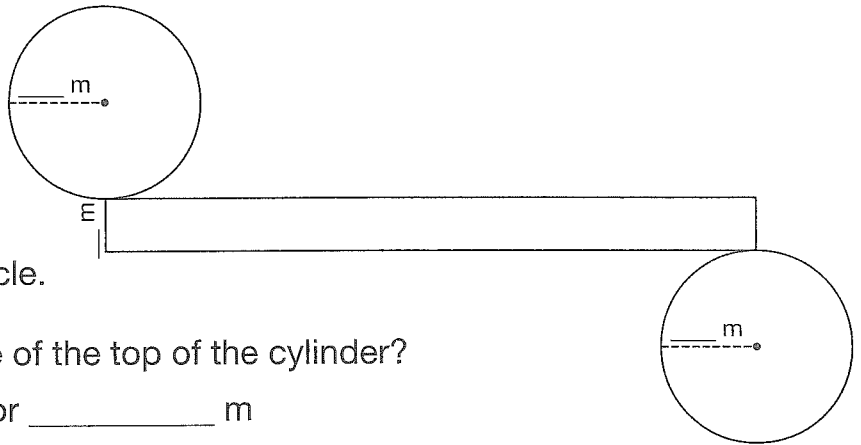

- B. What is the circumference of the top of the cylinder?

$$C = \pi \times 2 \times \underline{\hspace{2cm}} \text{ m, or } \underline{\hspace{2cm}} \text{ m}$$

- C. What part of the rectangle has the same measurement as the circumference of the circle?

- D. What are these areas?

$$A_{\text{rectangle}} = \underline{\hspace{2cm}} \text{ m} \times \underline{\hspace{2cm}} \text{ m, or } \underline{\hspace{2cm}} \text{ m}^2$$

$$A_{\text{circle}} = \pi \times (\underline{\hspace{2cm}} \text{ m})^2, \text{ or } \underline{\hspace{2cm}} \text{ m}^2$$

- E. What is the surface area to be painted?

$$SA_{\text{top + side}} = \underline{\hspace{4cm}}, \text{ or } \underline{\hspace{4cm}}$$

The surface area that needs to be painted is          m<sup>2</sup>, to the nearest square metre.

## Practice

1. Calculate the total surface area of this rectangular prism.

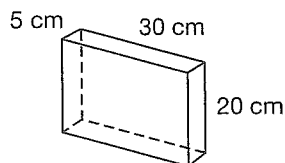

### REFLECTING

Why do you need the areas of three faces to determine the surface area of a rectangular prism?

2. What is the surface area of the rectangular prism for this net?

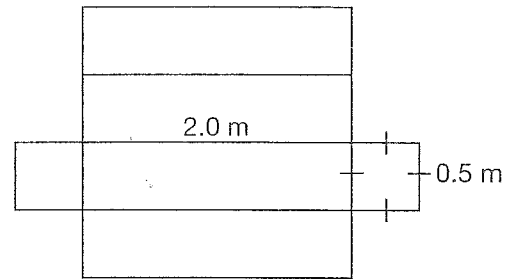

### REFLECTING

What does the surface area of a 3-D object have to do with the areas of 2-D shapes?

3. Draw a net for this cylinder. Record the dimensions on the net. Calculate the surface area, to the nearest square yard.

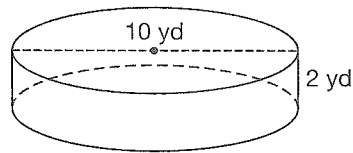

### Hint

The radius is half the diameter.

4. Jared is an engraver. A client has hired him to engrave slogans on novelty cubes. The side length of a cube is 20 cm. What is the total surface area for engraving?
- Sketch a net for the cube. Record the dimensions.
  - What is the area of one square face?
  - What is the total surface area of the cube?
  - How could you calculate the surface area of any cube?

$$SA_{\text{cube}} = \underline{\hspace{4cm}}$$

5. Jocelyn sells custom-made jewellery on her website. She is designing the box for shipping orders to her customers. She wants to make a box 9 in. long, 5 in. wide, and 3 in. tall. How much cardboard is needed, not including overlap?

### REFLECTING

How can sketching a net and recording the side lengths help you determine the surface area of an object?

6. Samantha looked up the formula for the surface area of a cylinder on two different websites. She found these formulas:

$$SA = \pi d(r + h) \qquad SA = 2\pi r^2 + 2\pi rh$$

- a) Show that both formulas give the same surface area for this cylinder.

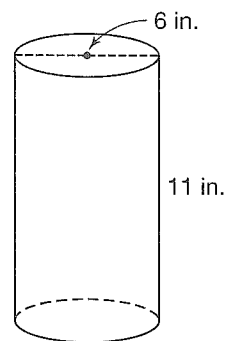

- b) Explain why both formulas give the same answer for any cylinder.

### REFLECTING

How is each part of the formula for the surface area of a cylinder related to the parts of the net?

7. Create and solve your own surface area problem.

# 3.2

## Surface Area: Prisms and Cylinders

### Try These

How can you make a net for an equilateral-triangle-based prism using 1 rectangle and 2 triangles?

#### Hint

Prisms and cylinders have two congruent bases and a lateral area.

#### lateral area

combined area of the side faces of a 3-D object

Marcy works for a toy company that sells sets of painted blocks. The company wants to find out which type costs less to paint. Which block has less surface area?

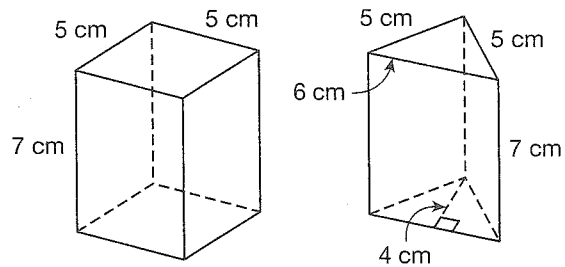

1 Complete the chart.

Type of block	Base area of block	Lateral area: base perimeter $\times$ height	Total surface area: $2 \times$ (base area) + lateral area
square-based prism	$5 \text{ cm} \times 5 \text{ cm}$ $= \text{ \_\_\_\_\_\_ } \text{ cm}^2$	$\text{ \_\_\_\_\_\_ } (5 \text{ cm}) \times \text{ \_\_\_\_\_\_ } \text{ cm}$ $= \text{ \_\_\_\_\_\_ } \text{ cm}^2$	$\text{ \_\_\_\_\_\_ } (25 \text{ cm}^2) + \text{ \_\_\_\_\_\_ } \text{ cm}^2$ $= \text{ \_\_\_\_\_\_ } \text{ cm}^2$
triangle-based prism	$\frac{1}{2}(6 \text{ cm})(4 \text{ cm})$ $= \text{ \_\_\_\_\_\_ } \text{ cm}^2$	$\text{ \_\_\_\_\_\_ } \text{ cm} \times \text{ \_\_\_\_\_\_ } \text{ cm}$ $= \text{ \_\_\_\_\_\_ } \text{ cm}^2$	$\text{ \_\_\_\_\_\_ } (\text{ \_\_\_\_\_\_ } \text{ cm}^2) + \text{ \_\_\_\_\_\_ } \text{ cm}^2$ $= \text{ \_\_\_\_\_\_ } \text{ cm}^2$

2 Which block has less surface area?

$\text{ \_\_\_\_\_\_ } \text{ cm}^2 < \text{ \_\_\_\_\_\_ } \text{ cm}^2$

The  $\text{ \_\_\_\_\_\_ }$  has less surface area.

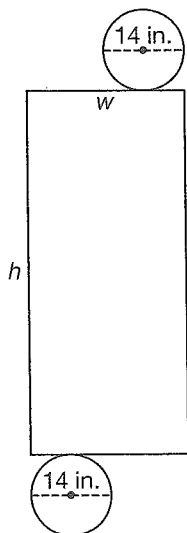

### Example

Karen is designing a plastic wrapper for a cylindrical roll of R-12 insulation. The surface area of the wrapper is 2375 sq in. What are the width and height of the rectangular part of her design, to the nearest inch?

#### Solution

A. What is the width of the rectangle?

Width =  $\pi \times \text{ \_\_\_\_\_\_ } \text{ in.}$ , or  $\text{ \_\_\_\_\_\_ } \text{ in.}$

The width of the rectangle is about  $\text{ \_\_\_\_\_\_ } \text{ in.}$



B. How can you use the formula for surface area to get the height?

$$SA_{\text{cylinder}} = 2 \times \pi \times (\text{ } \text{ in.})^2 + (\text{ } \text{ in.} \times h)$$

$$\text{ } \text{ sq in.} = \text{ } \text{ sq in.} + (\text{ } \text{ in.} \times h)$$

$$\text{ } \text{ sq in.} = \text{ } \text{ in.} \times h$$

$$\frac{\text{ } \text{ sq in.}}{\text{ } \text{ in.}} = h$$

$$\text{ } \text{ in.} = h$$

The height of the cylinder is  $\text{ } \text{ in.}$ , to the nearest inch.

**Hint**

Surface area formula for prisms and cylinders:  
 $SA = 2 \times \text{base area} + \text{lateral area}$

**REFLECTING**

How do you know the surface area formula above works for any prism or cylinder?

**Practice**

1. What is the surface area of each object?

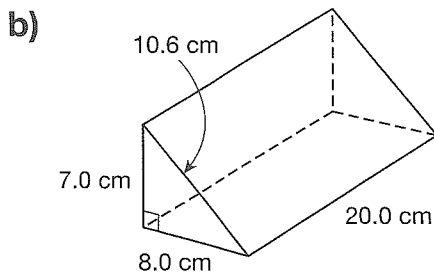
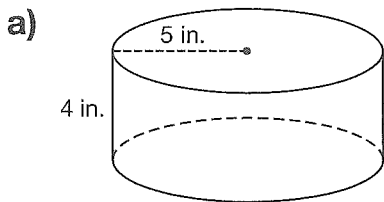

2. A steel cylinder is 100 cm long and has a radius of 5 cm. Cal determined its surface area but made some mistakes. Describe the errors. Then correct the solution.

~~Base area~~ =  $\pi(5 \text{ cm})^2$ , or  $15.707\dots \text{ cm}^2$

~~Base circumference~~ =  $2\pi(5 \text{ cm})$ , or  $31.415\dots \text{ cm}$

~~Lateral area~~ =  $100 \text{ cm} \times 31.415\dots \text{ cm}$ , or  $3141.592\dots \text{ cm}^2$

~~SA~~ =  $(2 \times \text{base area}) + \text{lateral area}$

~~=~~  $2(15.707\dots \text{ cm}^2) + (3141.592\dots \text{ cm}^2)$ , or  $3157.300\dots \text{ cm}^2$

# 3.3

## Surface Area: Pyramids and Cones

### Try These

Which triangle has a greater area?  
How do you know?

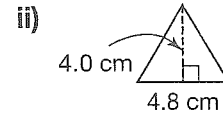
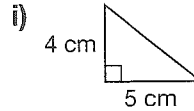

---



---

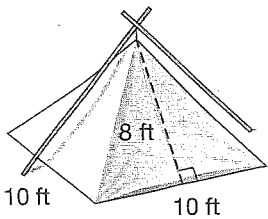

**slant height (pyramid)**

distance from the top of the pyramid to the centre of any side of the base

On canoe trips, Benoit packs two pieces of canvas to make this pyramid tent. One piece is for the walls. One is for the square floor.

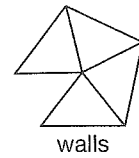

What is the least amount of canvas for the tent?

- Use this formula to determine the total area of the walls:

$$\text{Lateral area} = \frac{1}{2}(\text{perimeter of base})(\text{slant height})$$

$$\text{Lateral area} = \frac{1}{2}(\text{_____ ft})(\text{_____ ft}), \text{ or } \text{_____ sq ft}$$

- What is the total surface area of the tent, including the floor?

$$\text{_____ sq ft} + \text{_____ sq ft} = \text{_____ sq ft}$$

The least amount of canvas Benoit needs is \_\_\_\_\_ sq ft.

### REFLECTING

The area of a triangle is

$$\frac{1}{2}(\text{base})(\text{height}).$$

Why does it make sense that the formula for the lateral area of a pyramid is

$$\frac{1}{2}(\text{perimeter of base})(\text{slant height})?$$

### Example 1

A red cedar statue of a trout stands outside the Chamber of Commerce in Kamloops, British Columbia.

The stand is a metal cone. What area of metal is needed for the stand and its hidden base?

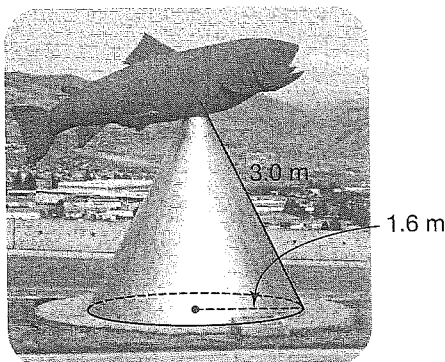
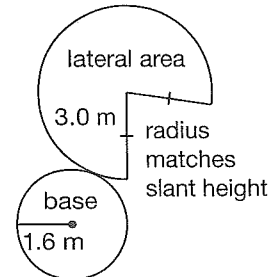

### Solution

- What is the area of the circular base of the cone?

$$\text{Area of base} = \pi r^2$$

$$= \pi(\text{_____ m})^2, \text{ or } \text{_____ m}^2$$

B. Use this formula to calculate the lateral area of the cone:

Lateral area =  $\pi rs$ , where  $r$  is the radius of the circular base and  $s$  is the **slant height of the cone**

$$\begin{aligned} \text{Lateral area} &= \pi rs \\ &= \pi(\text{_____})(\text{_____}), \text{ or } \text{_____ m}^2 \end{aligned}$$

**slant height (cone)**  
distance from the top of the cone to any point on the base circumference

C. What is the total surface area of the cone?

$$\begin{aligned} SA_{\text{cone}} &= \pi r^2 + \pi rs \\ &= \text{_____ m}^2 + \text{_____ m}^2, \text{ or } \text{_____ m}^2 \end{aligned}$$

D. How much metal was used to make the cone?

About \_\_\_\_\_  $\text{m}^2$  of metal was used to make the cone.

### Example 2

Amrita's company rents traffic cones. One cone is 28 in. tall and has a base radius of 7 in. What is its lateral surface area?

#### Solution

A. Use the Pythagorean theorem to determine the slant height,  $s$ .

$$\begin{aligned} s^2 &= (\text{_____ in.})^2 + (\text{_____ in.})^2, \text{ or } \text{_____ sq in.} \\ s &= \sqrt{\text{_____ sq in.}}, \text{ or } \text{_____ in.} \end{aligned}$$

B. What is the lateral surface area of the traffic cone?

$$\begin{aligned} \text{Lateral surface area} &= \pi rs \\ &= \pi(\text{_____ in.})(\text{_____ in.}) \\ &= \text{_____ sq in.}, \text{ or about } \text{_____ sq in.} \end{aligned}$$

The lateral surface area is about \_\_\_\_\_

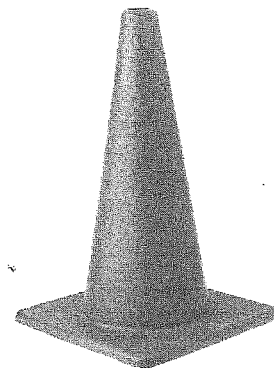

#### REFLECTING

Create a surface area problem about a cone or a pyramid. How could you solve your problem?

### Practice

- Complete the chart for this pyramid. The base has 2.0 in. sides. The slant height of each triangle is 10.0 in.

Pyramid base (side = 2.0 in.)	Base area (sq in.)	Lateral area (sq in.) $\frac{1}{2}(\text{perimeter})(s)$	Surface area (sq in.) (base area + lateral area)



## Mid-Chapter Review

1. The world's largest raisin box was built by students in California. The box is a rectangular prism 12 ft high, 8 ft wide, and 4 ft deep. What is its surface area?

2. These two steel rods are to be case-hardened. The process will cost more for the rod with greater surface area. Which rod will cost more to case-harden?

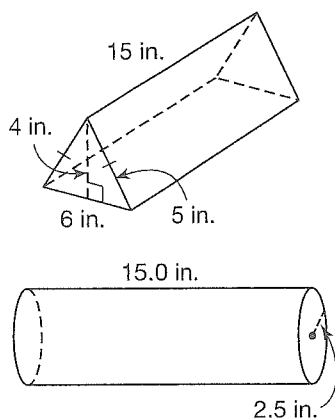

3. Tim works at a chocolate store. The store sells candy in two types of gift boxes. One is a square-based pyramid. The other is a cone. The one that uses less cardboard costs less to make. Both boxes have a slant height of 13.5 cm. Which box costs less to make?

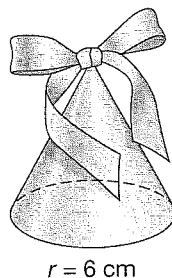
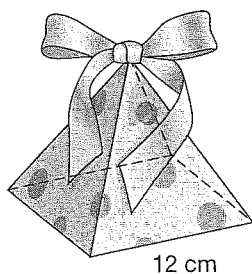

# 3.4

## Surface Area: Spheres

### Try These

#### You will need

- a ball
- string and a ruler, or a measuring tape
- scissors
- paper for wrapping

Use a small ball, such as a baseball or tennis ball.

- i) Measure the circumference: \_\_\_\_\_

Calculate the diameter to the nearest centimetre:

\_\_\_\_\_

- ii) Cut a rectangle so length = circumference of ball and width = diameter. Use the rectangle to wrap the ball. How do the two areas compare?

\_\_\_\_\_

An official NBA basketball has a circumference of 29.5 in. How much leather, to the nearest square inch, is needed for the surface?

### REFLECTING

If you know the surface area of a sphere, how can you determine the diameter?

What does this have to do with the formula in Question 3?

- 1 The surface area of a sphere matches the area of a rectangle you could wrap around it. How long would a rectangle need to be to wrap around an NBA basketball? \_\_\_\_\_ in.

- 2 How wide would the rectangle need to be?

$$\text{Diameter}_{\text{ball}} = (\text{_____ in.}) \div \pi, \text{ or } \text{_____ in.}$$

- 3 How much leather is needed for the surface?

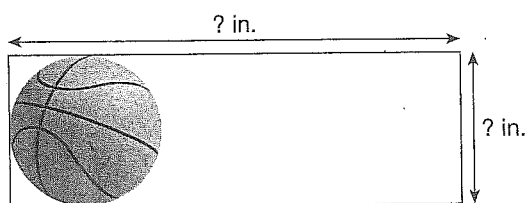

$$SA_{\text{ball}} = (\text{length of rectangle})(\text{diameter of ball})$$

$$SA_{\text{ball}} = (\text{_____ in.})(\text{_____ in.}), \text{ or } \text{_____ sq in.}$$

To the nearest square inch, \_\_\_\_\_ sq in. of leather is needed.

### Example

The circumference of a spherical gas storage tank is 50 m. What is the surface area of the tank?

### Tech Tip

When you divide by  $2\pi$ , use brackets:

$$50 \div (2\pi)$$

$$\pi \div (2\pi)$$

### Solution

- A. What is the radius of the storage tank?

$$2\pi r = 50 \text{ m}$$

$$r = \text{_____ m} \div (\text{_____ } \pi)$$

$$r = \text{_____ m}$$

B. What is the surface area of the tank? Use this formula:

$$SA_{\text{sphere}} = 4\pi r^2$$

$$= 4\pi(\text{_____ m})^2, \text{ or } \text{_____ m}^2$$

The surface area of the tank is about \_\_\_\_\_  $\text{m}^2$ .

### REFLECTING

The surface area of the rectangle that wraps a sphere is  $c \times d$ , or  $2\pi r \times 2r$ .

What does this have to do with the formula in Question 3?

## Practice

1. Complete the chart.

Radius ( $r$ )	Diameter ( $2r$ )	Circumference ( $\pi d$ , or $2\pi r$ )	Surface area ( $4\pi r^2$ )
50 cm			
	26 ft		

2. Cool Globes is a project designed to raise awareness of global warming. Artists decorate white globes to show ways to protect the environment. Each globe has a diameter of 5 ft. What area needs to be decorated for each sphere?

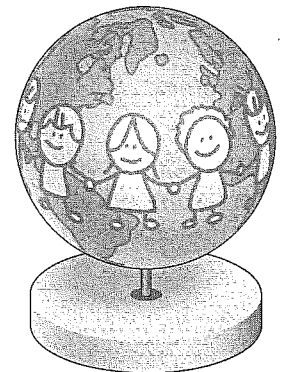

3. Jacques claims that another formula for surface area of a sphere is  $SA_{\text{sphere}} = \pi d^2$ . Is he correct? Justify your decision.

4. Sarah is installing security cameras. Each security camera is a sphere. The camera's surface area is 12.5 sq in. What is its diameter?

# 3.5

## Estimating Surface Area

### Try These

#### You will need

- a ruler
- 3-D objects  
(prisms, cylinders,  
pyramids, cones,  
spheres)

Estimate the surface area of this workbook.

---

---

Jeff is a cake decorator. A client ordered a cake shaped like a soccer ball for her son's 8th birthday. About how much surface area needs to be iced for the cake?

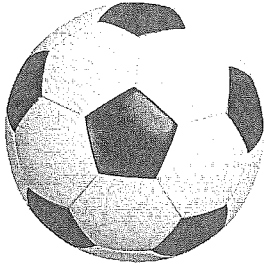

#### referent

a known measure used for comparing and estimating

#### REFLECTING

Why is it helpful to use a referent to estimate surface area?

- ① What square unit will you use to estimate the surface area of the cake? Give reasons for your choice.

---

---

---

- ② What is the surface area of the cake?

- ③ What **referent** did you use to estimate? How did you use it?

---

---

#### Example

Choose an object that is like a prism or a cylinder. How can you use a referent to estimate its surface area?

#### Solution

- A. Name the object. Describe the referent you plan to use.

Object: \_\_\_\_\_

Referent: \_\_\_\_\_

---



B. Estimate the surface area of the object. Explain your thinking.

---

---

---

## Practice

1. The front of a binder is about 1 sq ft. You can use this to help you estimate areas in square feet. Explain how to estimate the surface area of an object you can see in square feet.

2. Name a referent you could use to estimate areas in each unit. Describe the area of each referent.

a) square metres: \_\_\_\_\_

\_\_\_\_\_

b) square inches: \_\_\_\_\_

3. One gallon of paint covers about 200 sq ft. About how many gallons of paint would it take to repaint the walls and ceiling of your classroom?



4. Describe how a drywaller might use a formula to estimate the number of sheets of drywall needed for a room.

# 3.6

## Surface Area: Dimension Changes

### Try These

**You will need**

- a ruler

How does the area of a 2-D shape change when you double the side lengths? Check some examples. Then explain a rule.

---



---

Liana is a carpenter. She is making model pyramid-shaped trees out of plywood for a pavilion at a fair.

- All the pyramids have a square base with sides 4.9 m long.
- The slant heights of the pyramids vary from 5.5 m to 18.2 m.

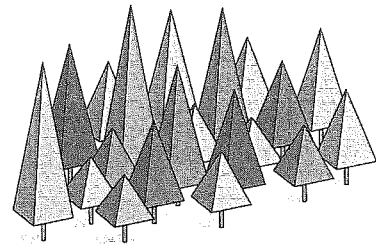

How much more plywood is needed for the largest tree than for the smallest?

1 Which face is the same on all the pyramid trees? \_\_\_\_\_

2 Which faces increase in size? \_\_\_\_\_

3 What is the surface area of the smallest pyramid tree?

$$\begin{aligned}
 SA_{\text{smallest tree}} &= (\text{base area}) + \frac{1}{2}(\text{perimeter})(s) \\
 &= (\text{ } \text{ m})^2 + \frac{1}{2}(4 \times \text{ } \text{ m})(\text{ } \text{ m}) \\
 &= \text{ } \text{ m}^2
 \end{aligned}$$

4 What is the surface area of the largest pyramid tree?

$$\begin{aligned}
 SA_{\text{largest tree}} &= (\text{base area}) + \frac{1}{2}(\text{perimeter})(s) \\
 &= (\text{ } \text{ m})^2 + \frac{1}{2}(4 \times \text{ } \text{ m})(\text{ } \text{ m}) \\
 &= \text{ } \text{ m}^2
 \end{aligned}$$

5 How much more plywood is needed for the largest tree, to the nearest square metre?

$$\text{ } \text{ m}^2 - \text{ } \text{ m}^2 = \text{ } \text{ m}^2$$

About  $\text{ } \text{ m}^2$  more is needed for the largest tree.

### REFLECTING

Why can you ignore the base areas when you are comparing the surface areas of the trees? Can you always ignore the base areas? Explain.

### Example

Maurice is an interior designer. He sees this spherical light fixture that costs \$40. Maurice wants to use a spherical light fixture with triple the radius of this one. What would be a fair price for it?

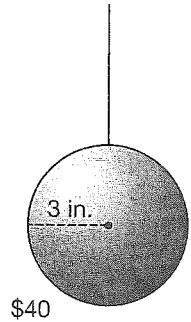

### Solution

A. What area of glass is needed for the smaller light?

$$SA_{\text{sphere}} = 4\pi r^2$$

$$= \underline{\hspace{2cm}} \pi (\underline{\hspace{2cm}} \text{ in.})^2, \text{ or } \underline{\hspace{2cm}} \text{ sq in.}$$

B. What area of glass is needed for the larger light?

Larger radius =  $\underline{\hspace{2cm}}$  ( $\underline{\hspace{2cm}}$  in.), or  $\underline{\hspace{2cm}}$  in.

$$SA_{\text{sphere}} = \underline{\hspace{2cm}} (\underline{\hspace{2cm}} \text{ in.})^2, \text{ or } \underline{\hspace{2cm}} \text{ sq in.}$$

C. What would be a fair price for the larger light? Explain.

The larger light has  $\underline{\hspace{2cm}}$  times as much glass as the smaller one, so the price should be  $\underline{\hspace{2cm}}$

### REFLECTING

Yvonne said the amount of glass tripled when the radius tripled. Why is this not correct?

(Hint: Think of the rectangle that wraps the sphere.)

### Practice

1. a) A manufacturer sells marbles in rectangular boxes. He wants to increase the size of the box. Complete the chart.

Box size	Base area	Lateral area (base perimeter $\times$ height)	Surface area 2(base area) + lateral area
original size: base: 4 in. by 5 in. height: 3 in.	4 in. $\times$ 5 in. = 20 sq in.	18 in. $\times$ 3 in. = $\underline{\hspace{2cm}}$	2(20 sq in.) + $\underline{\hspace{2cm}}$ = $\underline{\hspace{2cm}}$
all sides doubled: base: 8 in. by 10 in. height: 6 in.			
all sides tripled: base: 12 in. by 15 in. height: 9 in.			

b) Suppose you double the length and width of each face of the box. By what factor does the original surface area of each face change by?  $\underline{\hspace{2cm}}$



c) Suppose you triple the length and width of each face. By what factor does the original surface area of each face change by?  $\underline{\hspace{2cm}}$



## Solving a Surface Area Puzzle

# 3.7

Sal has 6 sticks. Each stick is 6 cm long.

- Sal is going to make the frame of a gift box without bending or breaking any of the sticks.
- Then he will cover the frame with paper.

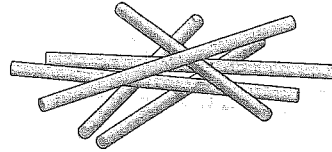

### You will need

- 6 sticks of equal length
- a ruler

A. What 3-D object can Sal make?

---

B. What is the least amount of paper Sal needs to cover the frame?

C. Suppose Sal used sticks that were twice as long. What would be the least amount of paper he could use?

D. Discuss your solutions with a partner.

- What strategies did you use to solve the puzzle?
- Did you both get the same solutions?

E. Marla said that if each stick used had a length of 3.0 cm, the least amount of paper would be  $31.2 \text{ cm}^2$ . Do you agree or disagree? Explain.

# Chapter Review

1. Which block of cheese has more surface area to wrap: the rectangular prism or the cylinder?

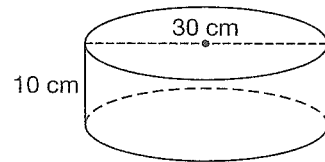
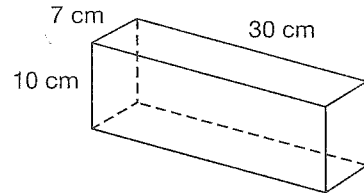

2. Which wooden block has more surface area to paint?

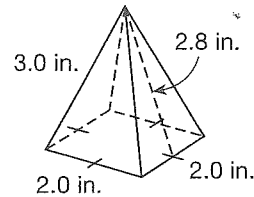
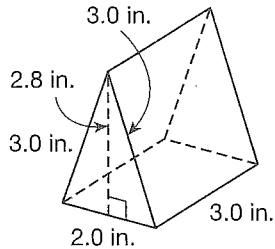

3. A box-shaped chest freezer has a surface area of  $5.1 \text{ m}^2$ . The freezer is  $1.2 \text{ m}$  long and  $0.7 \text{ m}$  wide. How tall is it?

4. Melissa is making this bird feeder with a metal roof for her craft store. She is leaving the cone open at the bottom. She needs to calculate the area of metal needed for the roof.

Melissa made an error when she calculated the area of metal. Describe the error. Correct the solution.

$SA(\text{roof})$  is the lateral area of cone

$$\begin{aligned} SA &= \pi rs \\ &= \pi(20 \text{ cm})(30 \text{ cm}) \\ &= 1884.955\dots \text{ cm}^2 \end{aligned}$$

I will need about 1880  $\text{cm}^2$  of metal for the roof.

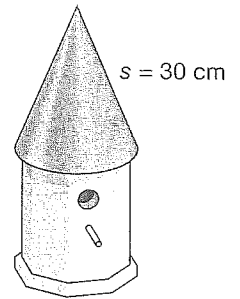

base diameter = 20 cm

5. The Aboriginal Pavilion at the 2010 Winter Olympics in Vancouver included a giant sphere with a radius of 32.5 ft. About how many square feet of material were used to cover the surface of the sphere?

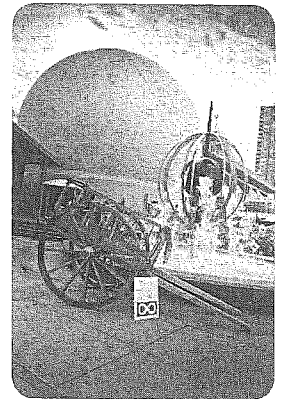

6. Choose an object you can see from your desk that looks like a prism, cylinder, sphere, pyramid, or cone. Estimate the surface area of the object. Show your steps.

7. The Flashline Mars Arctic Research Station (FMARS) on Devon Island in Nunavut is a research station where scientists explore what it might be like to live and work on Mars.

Suppose the station had a flat roof and no openings. What would be the surface area of the station, to the nearest square metre? Include the floor.

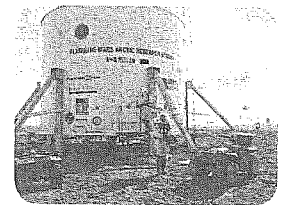

height = 9 m  
diameter = 8 m

# Chapter Test

1. Determine each surface area.

a) this giant chocolate bar

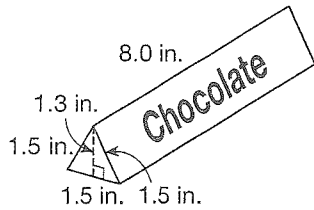

b) the Pyramid of Khafre, built on a square base

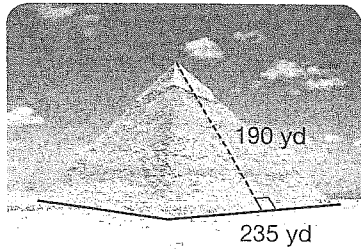

c) a cone with a slant height of 8 cm and a base radius of 3 cm

2. A cylindrical grain storage bin has a base radius of 5 m. The surface area is  $1099 \text{ m}^2$ . What is the height of the bin, to the nearest metre?

3. The diameter of the Omnimax Theatre at Science World in Vancouver is 47 m. If the theatre were a perfect sphere, what would its surface area be?

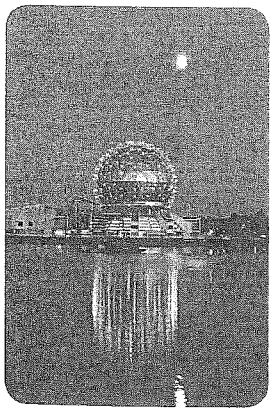

4. Suppose the length of the chocolate bar in Question 1 increased from 8.0 in. to 10.0 in. How would the surface area increase?